



TPC 15

15" Industrial Panel PC

Tueks Industrial Panel PCs are designed to work under severe conditions such as dusty-vibrating working environments and high temperatures. It is resistant to bumps. It is specially designed 1024x768 15" Color LCD screen provides easy operation. It can be used with Windows or Linux operating system.

Technical Specifications

Motherboard	Industrial, Mini ITX Motherboard (Fanless)
Processor	INTEL Cedar Trail-M
Storage Unit	64GB SSD
RAM	4GB DDR3L 1333Mhz (Max 4 GB)
RS232	4x
RS232/RS422/RS485	2x
10/100 /1000 Ethernet	2x
USB 2.0	3x
USB 3.0	1x
VGA Port	1x
Display	1024x768 15" LCD
Touch Screen	Resistive
SATA HDD Support	Yes
Operating Voltage	12V DC
Operating Humidity	%5 - %80 (Non-condensing)
Working Temperature	0 / 60°C
Power Consumption	60 W
Wi-Fi Support	Yes (USB)
3G Modem Support	Yes (USB)
Operating Systems	Windows (Optional), Linux
Dimension	376mm x 300mm x 56mm
Product Warranty	1 Year
Protection Class	IP65

Konzek Technology can make changes in product specifications without prior notice.

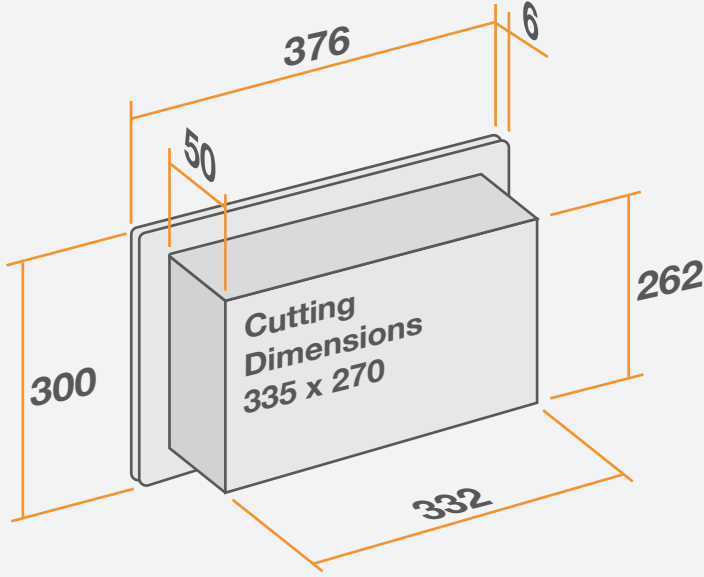

TPC151

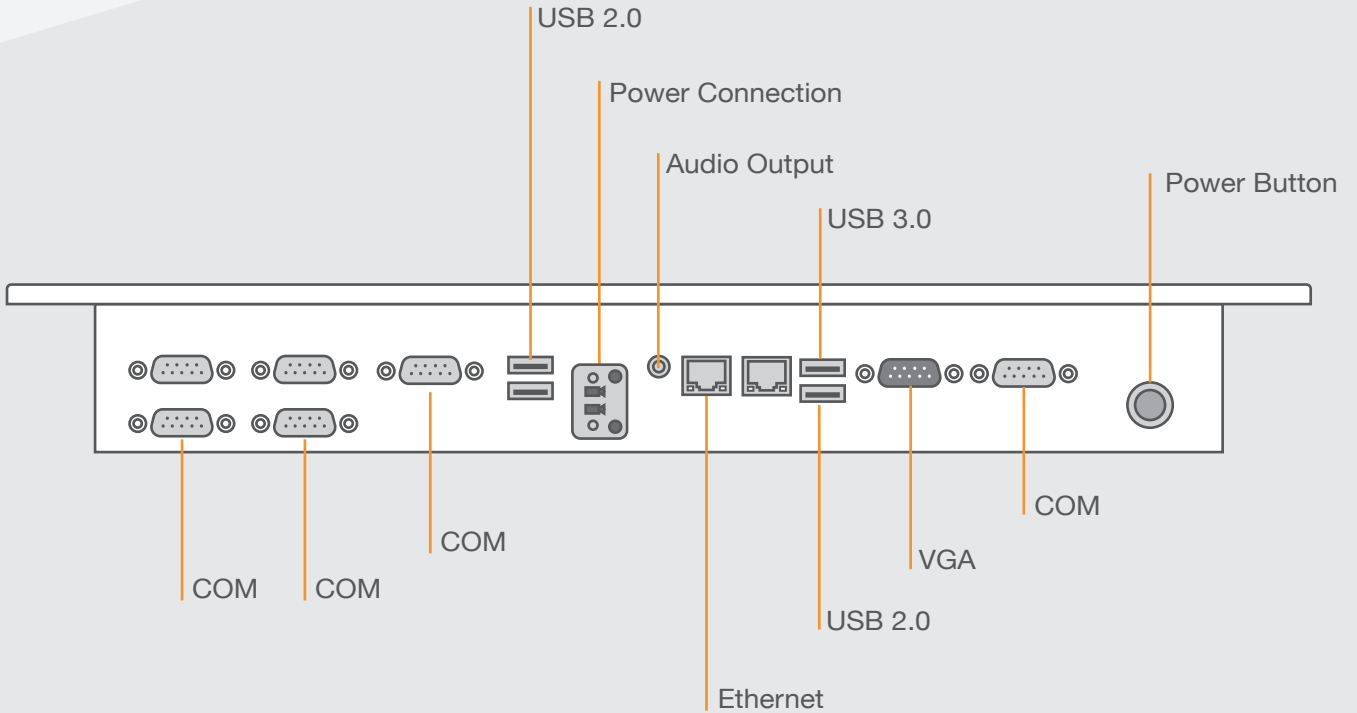

Konzek Technology can make changes in product specifications without prior notice.